

## 承認書

### SPECIFICATION

客戶名稱(CUSTOMER): 深圳市立创电子商务有限公司

產品名稱(PRODUUCT NAME): Y1 电容 WQC 品牌

威慶料號(WEIQING PART NO.): 011G2222M08DL23060

承認規格(APPROVE ITEM): 222M/400V P=10MM

客戶料號(CUSTOMER PART NO.):

送樣日期(SUBMIT THE SAMPLE DATE): 2018 年 6 月 21 日

產品尺寸(PRODUUCT SIZE):

樣品印字(SAMPLE PRINT):

## 威慶確認表

### WEIQING CONFIRM LIST

APPROVED	CHECKED	PREPARED
<u>Base</u>	<u>李林</u>	<u>叶德芬</u>

## 客戶承認結果

### CUSTOMER ACKNOWLEDGE THE RESULT

地址: 中国东莞松山湖高新技术产业开发区科技十路 7 号 12 栋

Add: Building 12, No. 7 Tenth Road of Science & Technology, DongGuan SongShan Lake High-tech Industrial Development Zone China TEL: 0769- 88956188/88956198 FAX: 0769- 88956168

**Approved/Recognized Type**

Related Standard		Certificate NO	APPROVED Monogram
CQC (China)	IEC 60384-14	CQC16001157279 CQC16001157069	
UL(usa) CSA(Canada)	IEC UL 60384	E466405	
ENEC (EU)	EN 60384-14	ENEC-40045528	
VDE (Germany)	EN 60384-14	40045529	

**Specifications**

Operating Temp.Range	-40°C to +85°C, -40°C to +125°C		
Applicable Standards	UL, CSA, CQC, ENEC, VDE	X1	Y1
		440VAC	400VAC
Dielectric Withstanding Voltage	Rted Voltage		Test Voltage
	400VAC		4000 VAC for 1 min.漏电流小于 5MA
Dissipation Factor (D.F)	Y5P,Y5U	TANδ(DF) ≤ 2.5%,measured at 1KHz±10%,1.0 - 5.0 Vrms,25°C	
	Y5V	TANδ(DF) ≤ 5.0%,measured at 1KHz±10%,1.0 - 5.0 Vrms,25°C	
Capacitance(C)	Range	10 pF to 4700 pF. measured at 1KHz±10%, 1.0 - 5.0 Vrms, 25°C	
	Tolerance	±10%	Y5P
		±20%	Y5U,Y5V
Insulation Resiatance(IR)	10000 MΩ , 1 min , 100 VDC		
Temperature Characteristics	Type Code	Temp. Coeff.	Temp. Range
	Y5P,Y5U	±10%, +22~-56%	-40°C to +85°C, -40°C to +125°C
	Y5V	+30%~-80%	-40°C to +85°C, -40°C to +125°C

### Ceramic Capacitor Part number system

The 18 digits part number is formed as follow:

1	2	3	4	5	6	7	8	9	10	11	12	13	14	15	16	17	18
O	1	1	G	2	2	2	2	M	8	0	E	L	2	0	0	1	0

#### Digit 1~3 Type Code

Code	Type	Code	Type	Code	Type	Code	Type
O11	Y1 Y5V	O21	NPO	O25	Y5V	O29	
O12	Y2 Y5V	O22	SL	O26	N750	O30	
O13	Y1 Y5P	O23	Y5P	O27	N3300	O31	
O14	Y2 Y5P	O24	Y5U	O28	Y5R	O32	

Code explain:

Code	TYPE	NOTS
Ceramic Safety Capacitors		
O11	Y1	X1/440Vac Y1/400Vac
O12	Y2	X1/400Vac Y2/300Vac
Ceramic Capacitors		
O21	NPO	0+/-60m\ppm/°C
O22	SL	+100~-1000ppm/°C
O23	Y5P	+/-10%
O24	Y5U	+22%-56%
O25	Y5V	+22%-82%
O26	N750	-750ppm/°C
O27	N3300	-3300ppm/°C
O28	Y5R	+/-15%

#### Digit 4~5 Rated Voltage Code

	A	B	C	D	E	F	G	H	J	K	L	M	N
1		12	16	20	25			50	63			1100	
2	100	125	160	200	250	315	400	500	630	800	120		
3	1000	1250	1600	2000	2500	3000	4000	5000	6000	8000	1200	1400	
	P	Q	R	S	T	U	V	W	X	Y			
1	240	300	330	440	540	600	700	850	900				
2	275	305	350	450	520		760						
3	280	310		480									

Explanation:Refer to JIS standard,Letter and then number indicate AC,but number and then Letter indicate DC,for example,2A indicate 100VDC,A2 indicate 100VAC.

**Digit 6~8 Capacitance Expressed in 3-digit code 3 Code**

The first 2digits indicate significant figures,and the third digit specifies the number of zero to follow.

This gives the capacitance in picofarads.

For examples:

$$102=10*10^2PF=1,000PF=1.0nF=0.001uF \quad 105=10*10^5PF=1,000,000PF=1000nF=1uF$$

**Digit 9 Capacitance Tolerance Code**

Tolerance	±0.25PF	±0.5PF	±5%	±10%	±20%	+50%/-20%	+80%/-20%	+100%/-0%
Code	C	D	J	K	M	S	Z	P

**Digit 10~11 Diameter Size Code****Diameter Type**

Diameter max(mm)徑	5.0	6.0	7.0	8.0	9.0	10.0	11.0	12.0	13.0	...
Case No.	05	06	07	08	09	10	11	12	13	***

**Digit 12 Lead Spacing Code**

Pitch	2.5	5.0	7.5	10	Special
Case No.	A	B	E	D	Z

**Digit 13 Lead Form Code****Lead Type**

Code	L	H	K	M	O	P	R	T	S
Lead Type	Long line	Short line	Inside of bending	Outside of bending	Double curved	Before and afterbecome warped line	The bending line	Taping	Customer Special Require

**Digit 14~16 Lead Length(Straight) and Tolerance of Lead Length(straight) and Expressed in 3-Letter Code**

Example: Code 035:35/10=3.5mm    230:230/10=23mm

**Digit 17~18 Internal use Color\material group\packing\ place of production**

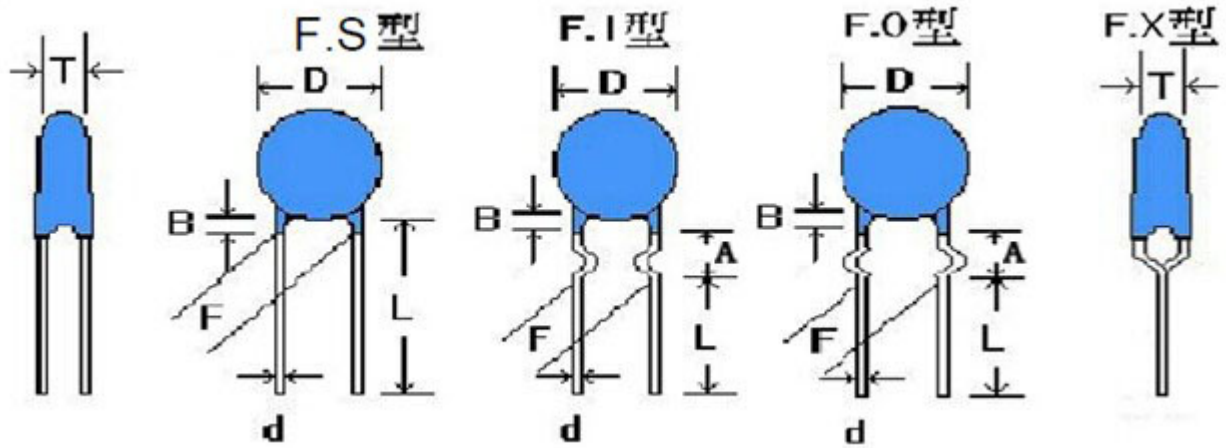

Dimensions and Tolerance

B=3.0mm max for AA

L=3-30mm

编带详细参数看 P11.

Approved Spec. Data

Name specification	D(MAX)	F±0.8	L( MIN) mm	T±0.5	d	B	A
Y5V 222M 400VAC	8.1	10	23	4	0.55	<2.5	<3.0

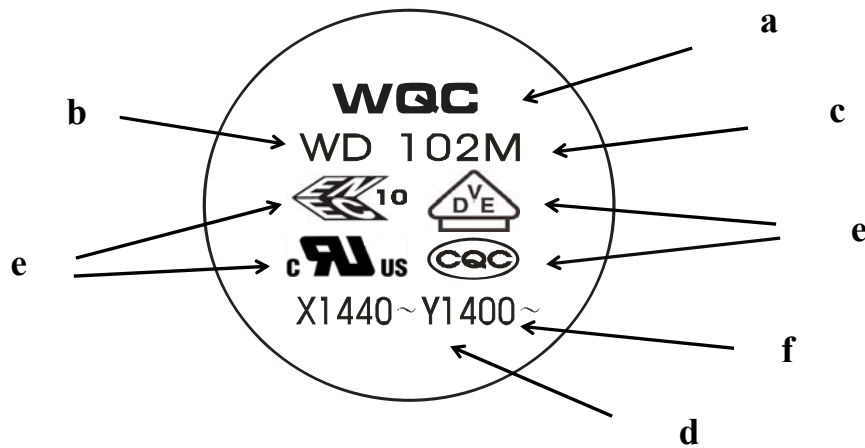

Marking:

- a. Company name code WQC
- b. Product Type WD Series
- c. Nominal Capacitance & Tolerance 102 = 1200pF, K= ±10%, M= ±20%
- d. Safety Class such as Y1
- e. Recognized Type
- f. Rated Voltage

**Packing Quantity:**

Packing	Safety	High Voltage	<i>Ceramic</i>
	Capacitor	Capacitor (Y1, Y2)	<i>Capacitor DC</i>
Bulk	1000Pcs	1000Pcs	1000Pcs
Tape Ammo	2000Pcs	1500Pcs	2000Pcs

ROHS Compliance , SVHC

EIA TEMPERATURE CHARACTERISTIC CHART		
Firs Digit is low Temperature	Second Digit is High Temperature	Last Digit is Capacitance Change Over Temperature Range From +25 C Reading
X: -55°C	4: +65°C	A ± 1.0 %
Y: -25°C	5: +85°C	B ± 1.5 %
Z: +10°C	6: +105°C	C ± 2.2 %
	7: +125°C	D ± 3.3 %
	8: +150°C	E ± 4.7 %
		F ± 7.5 %
		P ± 10 %
		R ± 15 %
		S ± 22 %
		T +22 % -33 %
		U +22 % -56 %
		V +22 % -82 %

**Capacitance Temperature Characteristics**

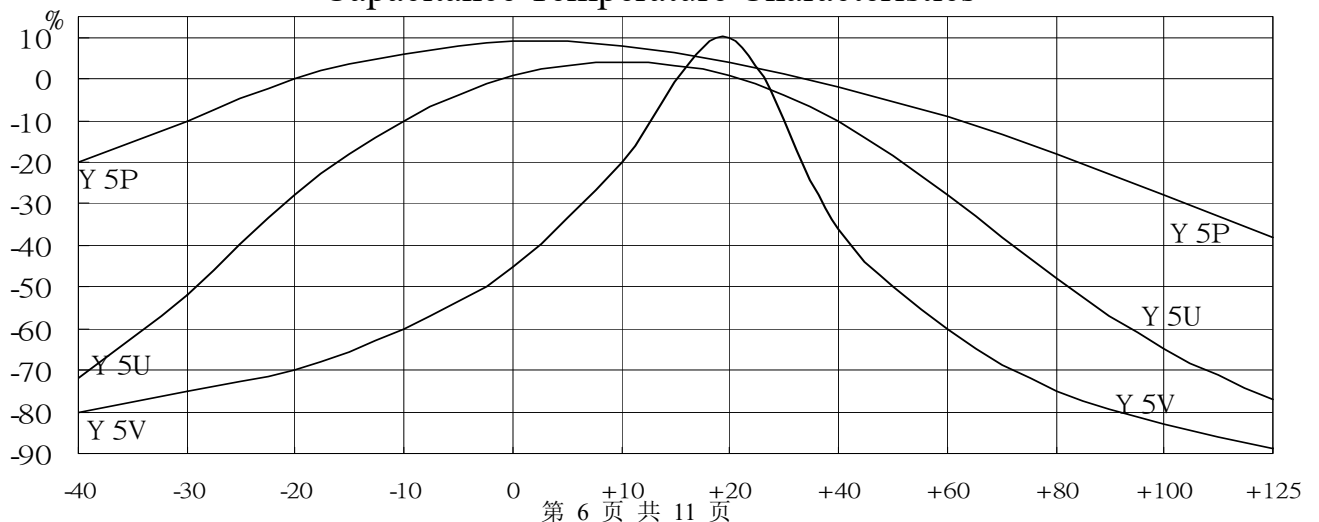

**Performance & Tests, draw up by IEC 60384-14:2005 and GB/T 14472**

"Note:(1) Is was defined according with IEC 60384-14:2005, when for qualification approval and periodic tests, the withstanding test must last to 1 minute, and it belong to destroyed test domain, therefore, after the test, capacitors should be scrap. Withstand voltage test should rise slowly at 150V/s, and test time is counted from when the voltage reaches to experiment requirement. (2) The test time is more than 1 second at production period, and the rated test voltage is applied.Capacitors may cause to damage when withstand voltage test repeated."

NO.	Item	Characteristic	Test Method	
1	Appearance and Dimensions	Please refer to figures and tables on page 2, 3 and 4.	1~1 1~2	"Production line visual inspection must be done in full and remove the defective products." "Dimensions measurement by micrometer and Caliper
2	Marks	Must be clean and clear.	2~1	Label need to be able endure wiping with Isopropanol
3	Withstand voltage test (I) Between terminal	Can not have exceptions.	3~1	Rated voltage: 300VAC for Y2, test voltage 2000 VAC or 2600 VAC, time 60s, frequency: 50Hz/60Hz. <b>Rated voltage: 400VAC for Y1, test voltage 4000 VAC, Approval and period test: 60s, Lot inspection 100% and time 2s, discharge current must <math>\leq 50</math> mA."</b>
	Between terminal and coating.	Can not have exceptions.	3~2	Use metal foil test method: use metal foil wrap around the capacitor body, each end extending at least 5mm, and keep 1mm/1kV distance minimum, between metal foil and terminals. for Y2, test voltage 2300VAC; for Y1, test voltage 4000VAC, test time 60s.
4	Withstand voltage test(III) (For safety symbol A2)	(1)Gauze shall not ignite. (2)Capacitors shall not in burned.	4~1	According to IEC 60384-14 and GB / T 14472 requirements.
5	Withstand voltage test (IV)(For safety symbol B2)	(3)Elements and coating must not scattered. (4)Terminals can not be moved away from the mounting position than 3mm.	5~1	According to IEC 60384-14 and GB / T 14472 requirements.
6	I Between terminals	More than 10000M $\Omega$ .	6~1	Measured voltage is $100 \pm 15$ V within 1 minute, and IR keeps within the specified value.
	R Between terminals and coating.	More than 10000M $\Omega$ .		
7	Capacitance	Within specified tolerance	7~1	The Capacitance shall be measured at 25°C, with $1 \pm 0.1$ kHz and 5Vrms max
8	Dissipation Factor(D.F)	B(Y5P) $\tan \delta \leq 2.5\%$ E(Y5U) $\tan \delta \leq 2.5\%$ F(Y5V) $\tan \delta \leq 5.0\%$	8~1	"The Dissipation Factor shall be measured at 25°C with $1 \pm 0.1$ kHz and 5Vrms max

NO	Item	Characteristic		Test Method			
9	Temperature Characteristic	Temperature Coefficient (T.C. category applicable):		9~1	Temperature Coefficient (T.C. category applicable):		
		TYPE Temp.Range	SL	YN	9~2	$\text{PPM}/^{\circ}\text{C} = (\text{Ct2} - \text{Ct1}) / \text{Ct1} * (\text{t2} - \text{t1})$ Ct2: the capacitance of t2 Ct1: the capacitance of t1 t2: 85°C±3°C t1: 20°C±2°C	
		20~85°C	+ 350~ -1000pp m°C	- 800~ -5800 ppm°C			
		Temperature characteristics: (High Dielectric applicable) Capacitance change rate within the range:  Type B Within ±10% Type E Within +22% -56% Type F Within +30% -80%		9~3	Temperature phase 1) 20±2°C → 2) -25±2°C → 3) 20±2°C → 4) 85±2°C → 5) 20±2°C Capacitance change: (High Dielectric Category applicable) $C.C(\%) = (\text{Ctx} - \text{Ct20}) / \text{Ct20} * 100$ Ctx : Except Temp. phase 1、3、5, The capacitance of any temperature between phase 2 to phase 4. Ct20: The capacitance of phase 3 temp.		
10	Robustness of terminations	Tensile	Lead wires not be snapped	10~1	Diameter (mm)	Load(kgs)	Time(sec)
					0.5Φ	0.5	10
					0.6Φ~0.8Φ	1	10
			Capacitors not be damaged	10~2	Fix the capacitor's body and apply a tensile weight gradually to each lead wire in the radial direction		
		Bending	Lead wires not be fractured Capacitors not be damaged	10~3	Diameter (mm)	Load(kgs)	Bending angle is 90 more than twice.
					0.5Φ	0.25	
	0.6Φ~0.8Φ			0.5			
11	Vibration resistance	Appearance	No significant abnormal	11~1	Vibration frequency from 10Hz to 55Hz and back to 10Hz, amplitude 1.5mm, period time within 1 minute.		
		Cap. Change	Within specification				
		Q or DF	Within initial specification				
12	Soldering Heat Resistance	Appearance	No significant abnormal	12~1	Solder temperature 350±10°C		
		Dielectric Strength	compliance with the characteristic as No.3	12~2	Immersion time 3.0± 0.5sec		
		Capacitance change rate	B: within ±10% E: within ±15% F: within ±20%	12~3	Placed at room condition for 4~24 hours, and then to measure.		



No.	Item	Characteristic	Test Method			
13	Solder ability	The round surface of lead wires, there must be 3/4 area welding with the solder.	13~1 13~2		Solder temperature 275±10°C Immersion time 2.0± 0.5sec	
14	Humidity (Under Steady State)	Appearance	No significant abnormal	14~1	Temperature: 40±2°C	
		Dielectric StrengthI	Must meet the requirements of No.3	14~2	Humidity: 90~95%RH	
		I R	Between terminals	More than the 1/2 value of No.6 requirements.	14~3	Time: 500±12 Hrs
			Between terminal& coating		14~4	Remove & placed at room condition for 1~2 hours, and then to measure.
		Capacitance change rate	Type B within ±15% Type E within ±20% Type F within ±30%			
		Dissipation Factor (D.F)	Type B & E, under 5%. Type F, under 7.5%			
15	Damp heat loading	Appearance	No significant abnormal	15~1 15~2 15~3 15~4 15~5 15~6	Temperature: 40±2°C Humidity: 90~95%RH Time: 500±12 Hrs Voltage: AC 180Vrms Current: Less than 50mA Remove & placed at room condition for 1~2 hours, and then to measure.	
		Dielectric StrengthI	Must meet the requirements of No.3			
		IR	Between terminals			More than the 1/2 value of No.6 requirements.
			Between terminal& coating			
		Capacitance change rate	Type B within ±15% Type E within ±20% Type F within ±30%			
		Dissipation Factor (D.F)	Type B & E, under 5% Type F, under 7.5%.			

No	Item	Characteristic		Test Method		
16	Endurance	Appearance		16~1	Temperature: 85±3°C; 125±5°C  Time: 1000±12 Hrs  Voltage: rated voltage of 1.7UR  Current: less than 50mA  Remove & placed at room condition for 1~2 hours, and then to measure.	
		Dielectric StrengthI		16~2		
		I R	Between terminals	More than the 1/2 value of No.6 requirements.		16~3
			Between terminal&coating			16~4
		Capacitance change rate		16~5		
		Dissipation Factor (D.F)				
17	Flame Test		Applicable safety symbols A2, B2.		The capacitor should be subjected to applied flame for 15 sec, and then removed for 15 sec, until 3 cycles are completed. And then continued to flame a minute and never to explode.	
18	Solvent Resistance (Body)		After the test must meet the standards of its electrical properties		The capacitor should be immersed into a isopropyl alcohol for 5±0.5 minutes, then removed and placed for 48 hrs. at room condition before post measurements.	
19	Solvent Resistance (Mark)		Marks should be legible		Use cotton yarn dips isopropyl alcohol, by force 5±0.5 N/1 cm <sup>2</sup> , 1 second round trip twice to wipe mark on the body, and run 5 cycles.	

# TAPING SPECIFICATIONS

Taping (Radial)--Lead Spacing F=7.5±0.8 or 10.0±0.8

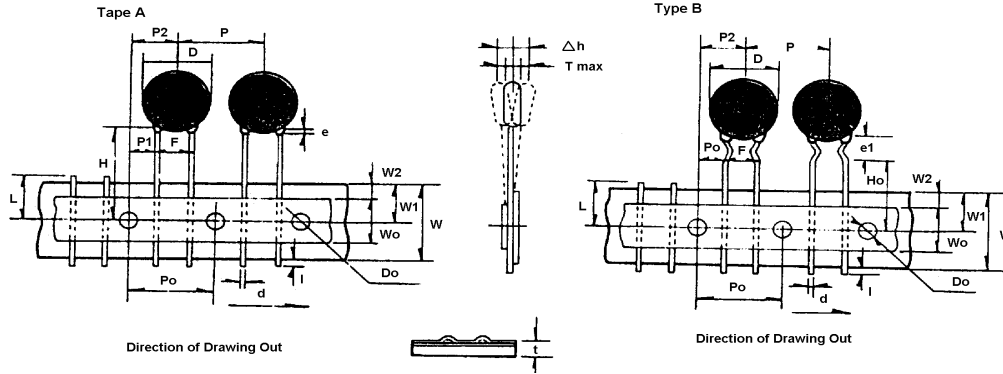

Item	Code	Dimensions (mm)	Item	Code	Dimensions (mm)
Taping Pitch	P	12.7±1.0	Lead Protrusion	l	+0.5~1.0
Guide Pitch	Po	12.7±1.0	Diameter of Feed Hole	Do	4.0±0.3
Lead Spacing	F	5.0±0.8 7.5±0.8 9.5±0.8	Diameter of Lead	d	0.55+0.06-0.05
Feed Hole Position Capacitor Body	P2	6.35±1.3	Total Thickness of Tape	t	0.7±0.2
Feed Hole Position Capacitor Lead	P1	3.85±0.7	Thickness of Capacitor Body	T	Differ in each product
Diameter Of ISO	D	See table of each series	Alignment to FR. Direction	Δ h	0±2.0
			Length of snapped Lead	L	3.5 ± 0.3mm
Width Of Base Tape	W	18.0±0.5	Width of Hold-down Tape	W0	12.5
Feed Hole Vertical Position	W1	9.0 +0.75 -0.05	Hold-down Tape Position	W2	1.5±1.5
Taping Height	For Straight	Ho	Coating Extention	e	3.0 以下
	For Crimp	H		e1	up to center of crimp

## AMMO PACK

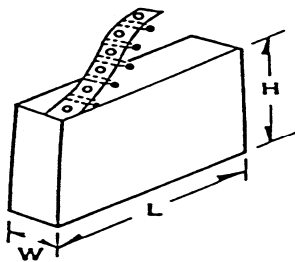

H = 241±5 mm  
L = 332±5 mm  
W = 42 ± 3 mm

Acceptable to standard radial type cartridge.

## REE

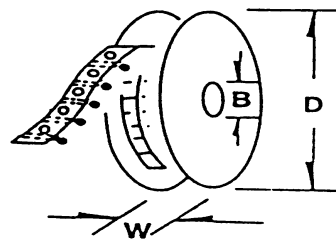

D ≦ 354(13.93)  
B ≦ 21(.83")but  
≦ 30(1.18")  
W ≦ 55(2.16)

Acceptable to standard radial type cartridge with a few extra accessories. Reeled axials are also acceptable to standard axial type cartridge with a few accessories.